

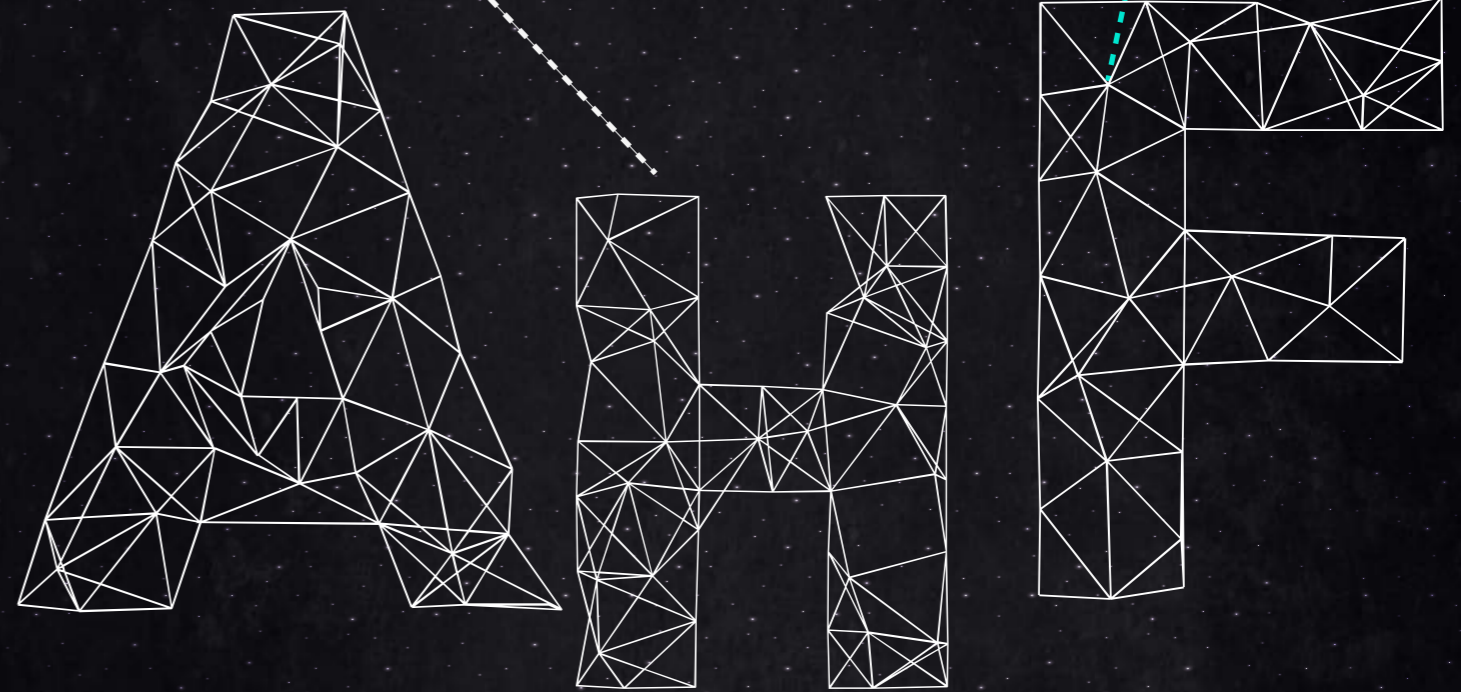

Sinexcel

Power Quality

Energy Efficiency



Flexible Alternative Current
Harmonic Mitigation

Inverter Based PQ
Active Harmonic Filter

Modular
Solution



Front View

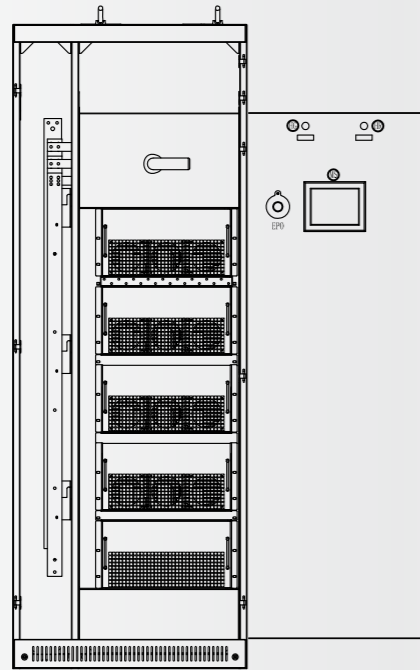

Left Side View

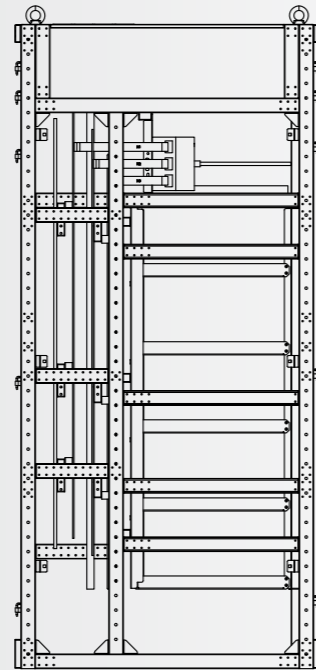

NONLINEAR LOADS

Different compensation model for different loads



NONLINEAR LOADS

INDUSTRIAL EQUIPMENT

Induction furnaces, static converters, VFD, welding machines

OFFICE EQUIPMENT

Computers, servers, printers

HOUSEHOLD APPLIANCES

Fluorescent lightings, TV light, dimmers, microwave ovens.

UNINTERRUPTIBLE POWER SUPPLIES (UPS)

WHY HARMONIC HURT YOUR SYSTEM?

Higher harmonic current would lead to capacitors' inner swelling, oil spilling and fire risk, severe discharge, flashover and overheat, resulting in over-current and over-voltage, accelerating the aging of the capacitor dielectric, lower safety levels of installations, which cause the unnecessary financial losses.

Higher harmonic orders cause more serious distortion on the grid voltage and current, which will increase the transformer copper and iron losses or load imbalance.

Affect the equipment efficiency and occupy unnecessary grid capacity. Overheating of equipment and shortening the lifetime.

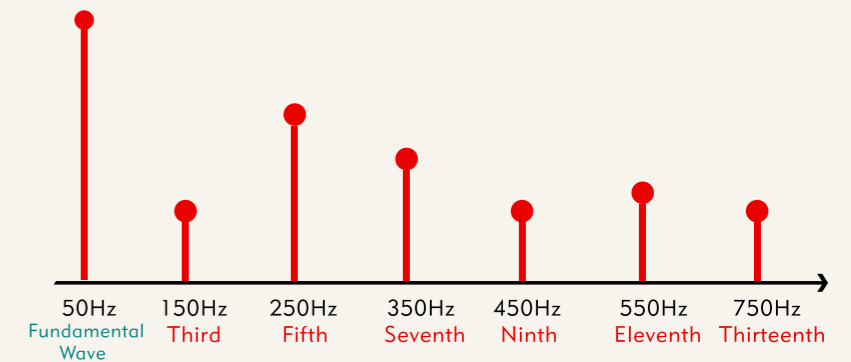

Electrical network with poor power quality results in financial loss and safety concerns. Good power quality not only improves the efficiency of the energy by decreasing the loss of electrical equipment, but also guarantees that the power system could support stable and healthy operation. It becomes more and more convenient for us both in daily life and industry because of fast developing technology, which is also accompanied with the development of non-linear loads.

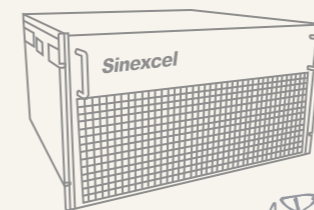

AAI Inverter Base

AHF WORKING PRINCIPLE

Optimize your harmonic compensation efficiency

- Flexible Alternative Current
- Harmonic Mitigation
- Inverter Based PQ
- Active Harmonic Filter

External CT detect the load current, DSP as CPU has advanced logic control arithmetic, could fast track the instruction current, divides the load current into active power and reactive power by using the intelligent FFT, and calculates the harmonic content rapidly and accurately. Then sends PWM signal to internal IGBT's driver board to control IGBT on and off at 20KHZ frequency. Finally generates opposite phase compensation current on inverter induction, at the same time CT also detects the output current and negative feedback goes to DSP. Then DSP proceeds the next logical control to achieve more accurate and stable system.

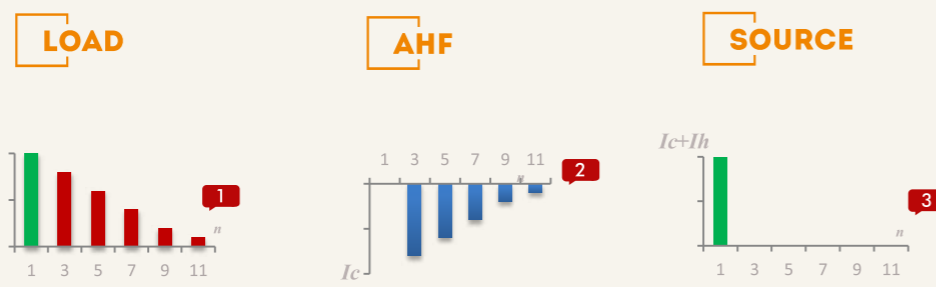
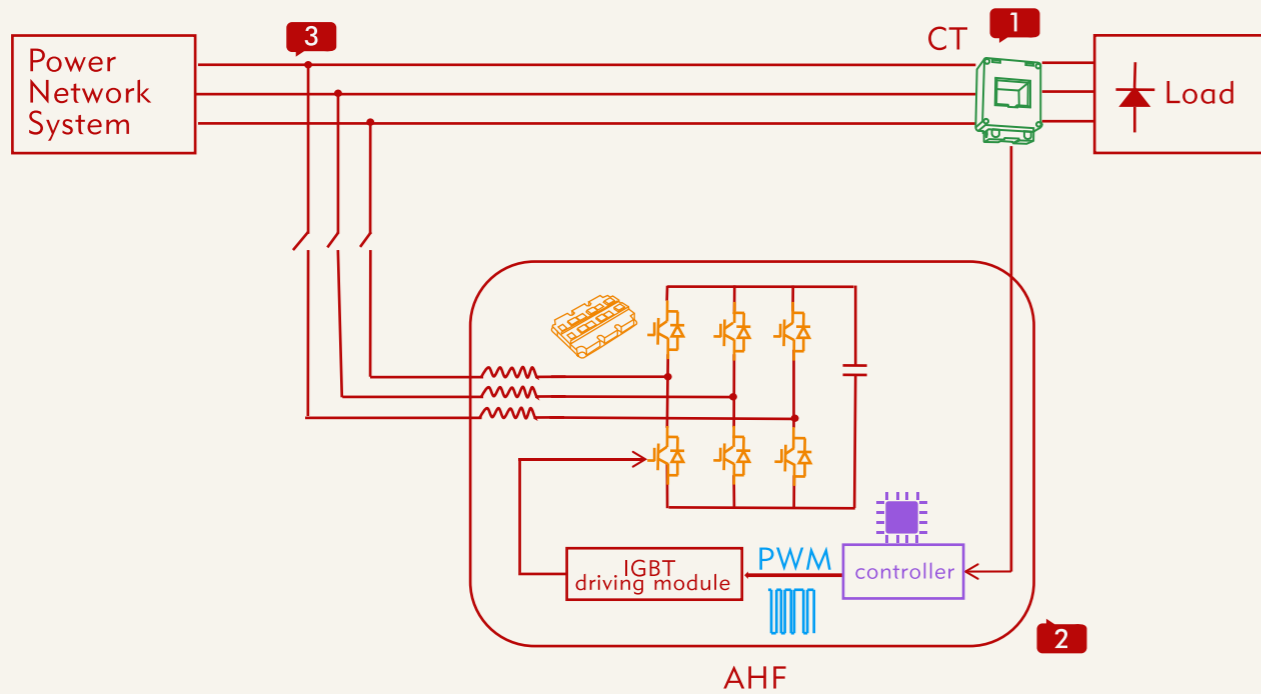

SPECTRUM

WAVEFORM

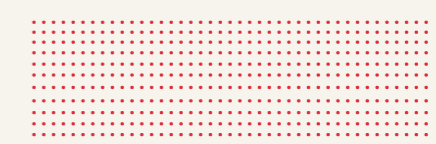
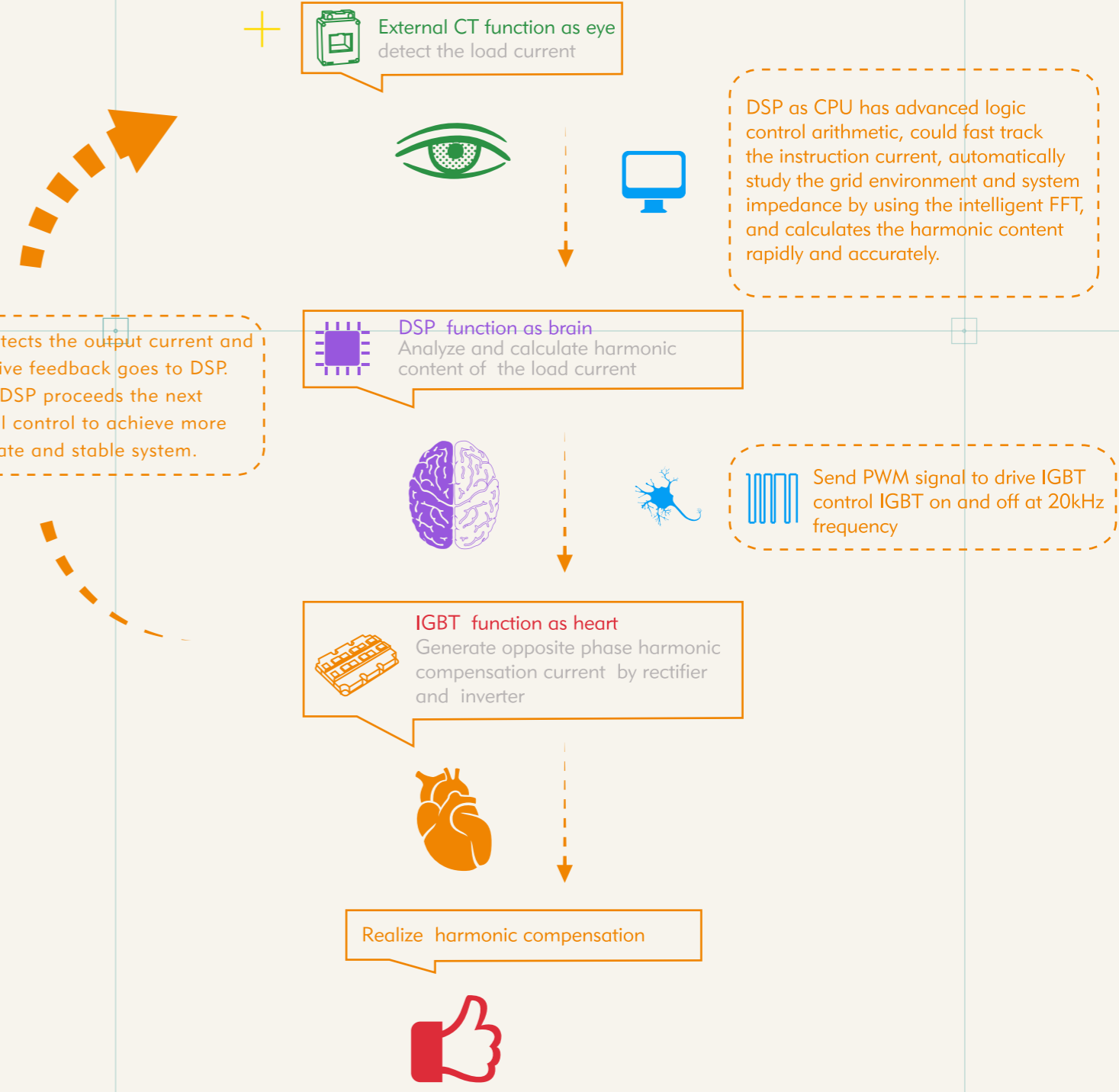

UNDERSTAND HOW AHF COMPENSATE HARMONIC

Optimize your harmonic compensation efficiency

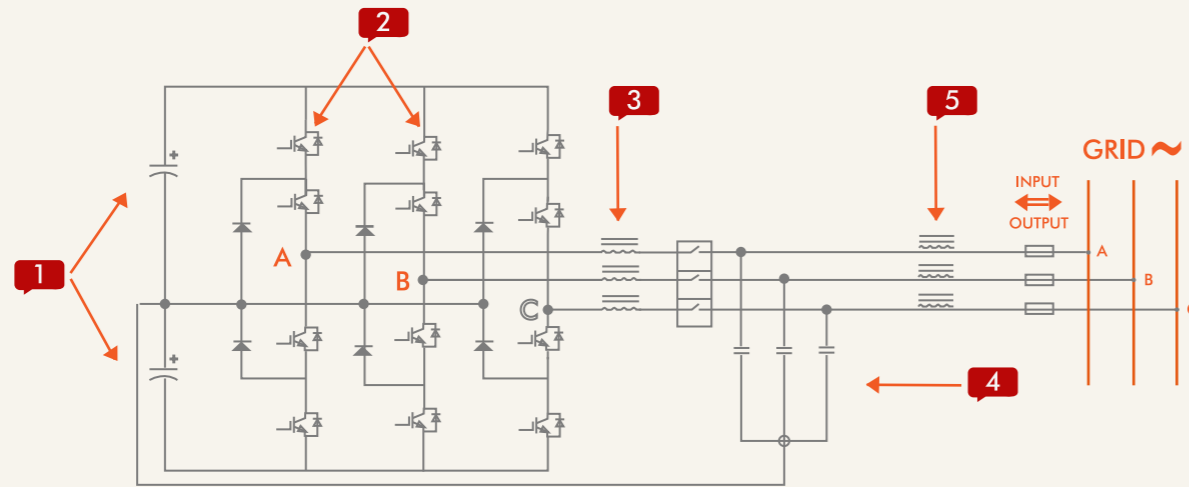

DC BUS CAPACITOR

AC to DC rectifier storage

IGBT

Controlled by DSP software algorithm, IGBT on-off timing selection and length could control inverter to generate a harmonic current.

IGBT generates square wave, it's outline is like sinusoid.

INVERTER INDUCTION

The square wave will convert into triangular wave, which is more like sinusoid after inverter inductor.

LCL FILTER CIRCUIT

LC FILTER CIRCUIT

LC filter circuit filter out impurities of the harmonic. High frequency inductor The rest of high frequency harmonic will be filtered by the high frequency inductor.

HIGH FREQUENCY INDUCTOR

Both for filtering. The combination of LC filter circuit and high frequency inductor are called LCL filter circuit

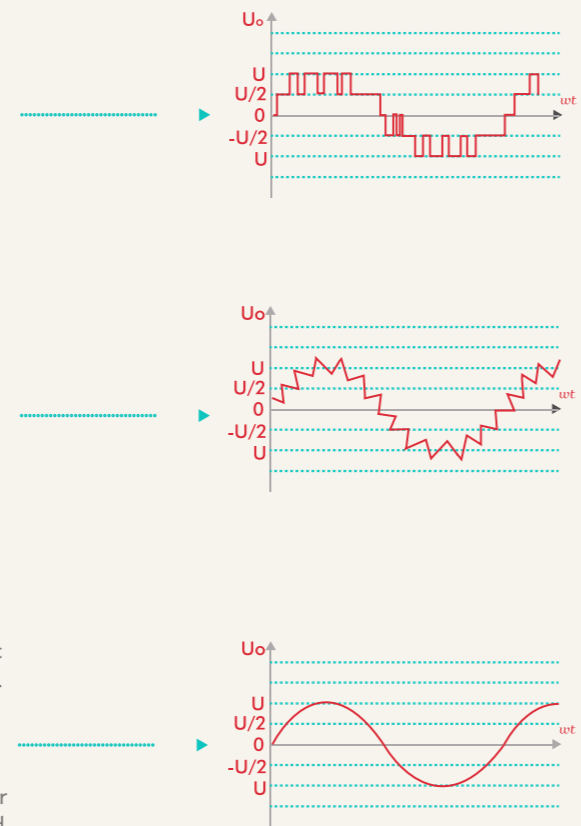

KEY FEATURES AND BENEFITS

Impressive compensation effect of AHF

MODULAR DESIGN

Ultra-compact design, wall and rack mount installation, easy to use in new or exiting switch room upgraded

Module structure with highest reliability of system

3P4W and 3P3W adapted by same modules, same harmonic mitigation capability

INTELLIGENT FFT

Unique intelligent FFT algorithm automatically study the electrical system impedance, to prevent system from resonance, high system reliability

Real time electrical system resonance monitor and management

GRAPHICAL USER INTERFACE

Module 4.3 inch HMI, cabinet 7 inch HMI central

Display electrical system voltage, current, frequency, before and after THDi, Apparent/Active/Reactive power, etc

Display before and after waveform, spectrum in same page with clearly comparison

MAINTENANCE FREE DESIGN

Independent air flow, separate electronic components from air flow Free of dust cleaning maintenance requirement, improve product reliability

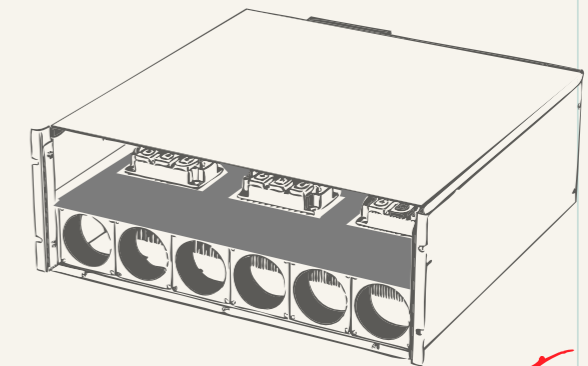
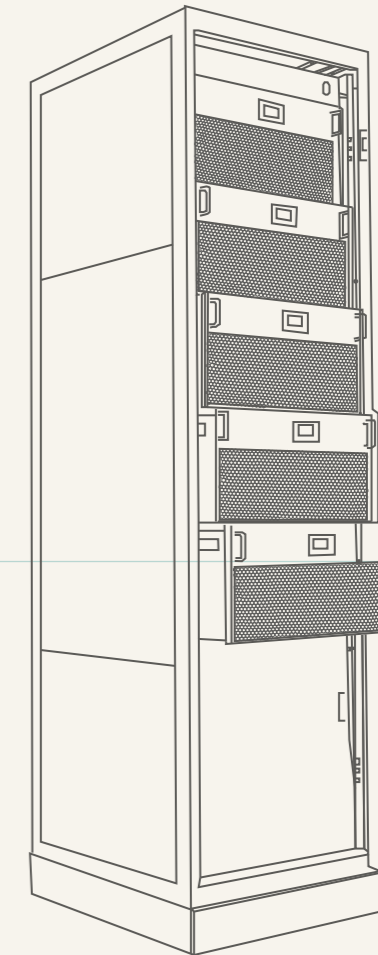

AHF Cabinet

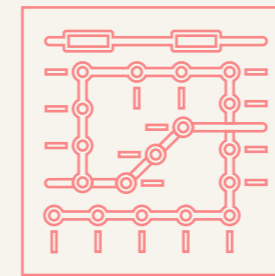

POWER INVERTER

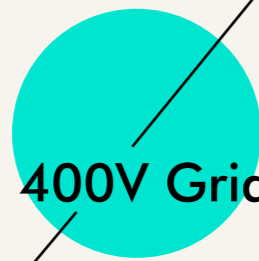
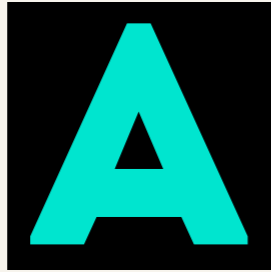
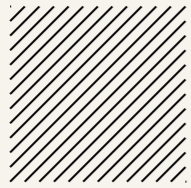

400V Grid Voltage

Specification

Item	
Nominal voltage	
Voltage range	
Nominal frequency	
Paraller quantities	
Efficiency	
Wiring configuration	
Current Transformer	
Topology	
Capacity	
Harmonic Comp.	
Reactive Power Comp.	
Unbalance Comp.	
Compensation Har. Order	
Harmonic compensation rate	
Fast response Time	
Overall response Time	
Target PF	
Overall response Time	
Switching frequency	
Cooling (Smart ventilation)	
Noise level	
Communication port	
Communication protocol	
Display interface	
Protecting	
Event recorded	
Installation	
Dimension (W * D * H, mm)	Rack mount, LED
	Rack mount, LCD
	Wall mount, LCD
Net weight	
Color	
Altitude	
Operation temperature	
Relative humidity	
Protection class	
Qualifications	

Sinexcel Active Harmonic Filter						
AHF 5/10/15	AHF 25/35	AHF 50/60	AHF 75	AHF 100	AHF 150	AHF 300
System Parameters						
400V						
228-456Vac						
50/60Hz (Range : 45Hz ~ 62.5Hz)						
Unlimited						
≥ 97%						
3 Phase 4 Wire/3 Phase 3 Wire						
0 ~ 30,000/5						
Three level						
Performance Indicators						
5/10/15A	25/35A	50A/60A	75A	100A	150A	300A
Default						
Default						
Default						
2-61 order						2-50 order
> 95%						
<20μs						< 50μs
< 5ms						
-1 ~ 1 adjustment						
FFT, intelligent FFT, and instantaneous reactive power						
average 50kHz	average 20kHz					
44L/Sec	151L/Sec	115L/Sec	222L/Sec	336L/Sec	360L/Sec	500L/Sec
<68dB	<56dB				<65dB	<75dB
Monitoring						
RS485 , Ethernet(option)						
Modbus, TCP/IP(option)						
Wifi display 7-inch HMI(optional)	4.3-inch LCD touch panel ; LED indicator, central monitor(optional 7-inch touch screen)					
over-voltage protection, under-voltage protection, inverter bridge inverse protection, over-compensation protection, and etc						
Yes , max. up to 500 records						
Mechanical Characteristic						
Wall mounted / Rack mounted	Wall mounted / Rack mounted / Cabinet					
410*340*45	440*490*150	500*515*180	500*546*190	500*575*200	500*605*269	500*726*370
/	440*490*150	500*515*180	500*586*190	500*605*200	500*630*269	500*726*370
410*45*340	440*150*485	500*180*540	500*190*571	500*200*599	500*273*638	500*370*729
4.98kg	18kg	23kg	28kg	35kg	44kg	110kg
Black	Black					
Environment Requirement						
≤ 1500m						
1500 ~ 4000m (according to GB/T3859.2 , increase every 100m derating capacity 1%)						
-10°C ~ +40°C						
5% to 95%, non-condensing						
IP20 , others IP class could be customized						
CE						

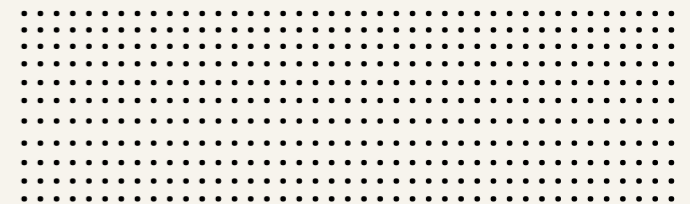

INVERTER



North America
& 690V Grid voltage



Specification

Items	208V	480V	600V	690V
	Sinexcel AHF 25/35/50/60/75/	Sinexcel AHF 25/35/50/60/75/90/100	Sinexcel AHF 25/35/50/60/75/90/100	Sinexcel AHF 25/35/50/60/75/90/100
System Parameter				
Rated input	220V(176V~264V)	480V(384V~552V)	600V(420V~690V)	690V(483V~793V)
Power grid frequency	50/60Hz (range: 45Hz~62.5Hz)			
Parallel quantities	Unlimited			
Efficiency	>97%			
Power grid structure	3P3W/3P4W			
CT	150/5~30,000/5			
Circuit topology	3-Level			
Performance Indicator				
Rated capacity	25/35/50/60/75/90/100A			
Function	Harmonic compensation, Reactive power compensation, Unbalance compensation			
Control algorithm	FFT/ Intelligent FFT/ Instantaneous Reactive Power			
Filtering range	2 nd to 50 th orders			
Filtering performance	>95%			
Reaction time	<50μs			
Overall response time	<5ms			
Target power factor	Adjustable from -1 to +1			
Switching frequency	Average 20KHz			
Cooling air requirement	359L/Sec	For 25/35/50A 342L/Sec; For 60/75/90/100A 359L/Sec		
Noise level	<65dB			
Communication & Monitoring Capability				
Communication ports	RS485, Ethernet port (RJ45)			
Communications protocols	MODBUS (RTU, TCP/IP)			
Module display interface	7-inch LCD touched screen(LED(rack-mounted); 4.3-inch LCD touched screen(wall-mounted)			
Protection functions	Abnormal voltage/frequency protection; Inverter short-circuit protection; Abnormal output current protection; Inverter over-loaded protectio; Over-tempearture protection etc.,			
Monitoring alarm	Available			
Fault alarm	Available, 500 alarm records			
Machanical Properties				
Mounting type	Wall-mountedd/Rack-mounted/Cabinet			
Dimensions (WxDxH)mm	For 25A/35A/50A		For 60/75/90/100A	
	500*540*180 (Rack-mounted)	500*184*627 (Wall-mounted)	500*675*250 (Rack-mounted)	500*250*723 (Wall-mounted)
Net weight	70kg	40kg (25/35/50A); 70kg (60/75/90A/100A)		
Color	Black			
Environment Requirement				
Altitude	≤1500m; Between 1500m to 4000m, derating 1% every additional 100m			
Ambient temperature	-20°C~40°C (may derate capacity if ambiet temperature exceeds 45°C)			
Relative humidity	5% to 95%, non-condensing			
Protection class	IP20			
Related Qualifications & Standards				
Qualifications	CE, cETLus, cULus, DNV/BV/RINA			
Standards compliance	IEEE 519, ER G5/4, IEEE 61000			

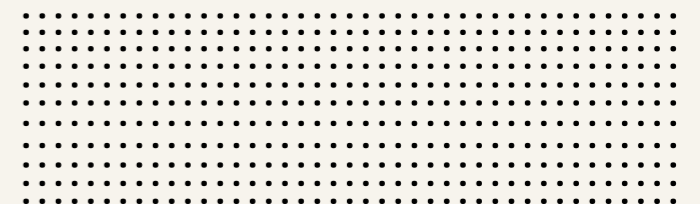

POWER
EFFECT
AVANT



400V



○ 25A/35A wall 440*150*485mm³ 18kg
 rack 440*490*150mm³ 18kg

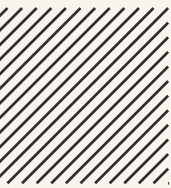

400V



○ 50A/60A wall 500*180*540mm³ 23kg rack 500*515*180mm³ 23kg
 75A wall 500*190*571mm³ 28kg rack 500*546*190mm³ 28kg
 100A wall 500*200*599mm³ 35kg rack 500*575*200mm³ 35kg

PREMIER SERIES AVANTAGE

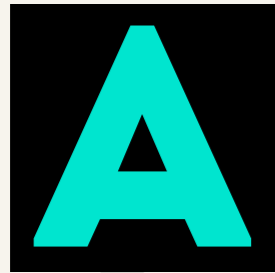

400V



300A wall 500*273*638mm³ 110kg
rack 500*370*729mm³ 110kg



150A wall 500*273*638mm³ 44kg
rack 500*605*269mm³ 44kg



50A wall 500*184*627mm³ rack 500*540*180mm³ 40kg
90A wall 500*253*590mm³ rack 500*590*250mm³ 62kg
100A wall 500*250*723mm³ rack 500*675*250mm³ 70kg



480V
600V
690V

POWER
INTELLIGENCE

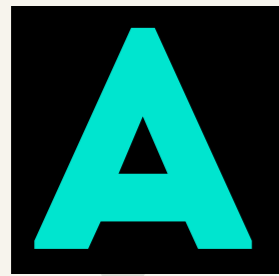

400V



5A/10A/15A wall/rack 410*340*45mm³ 4.98kg



400V



Flexible Engineering Cabinet

- Flexible dimension
600*1000*2200mm³, 800*1000*2200mm³, 800*800*2200mm³, 1000*1000*2200mm³ are available.
- Flexible Capacity
AHF, 25A/35A/50A/60A/75A/100A/150A/300A adapt to cabinet
SVG, 30kvar/50kvar/100kvar/200kvar adapt to cabinet
AHF, SVG module adapt to cabinet
- Flexible incoming connection
Top / Bottom cable entrance
Top / Bottom MCCB position

MONITORING

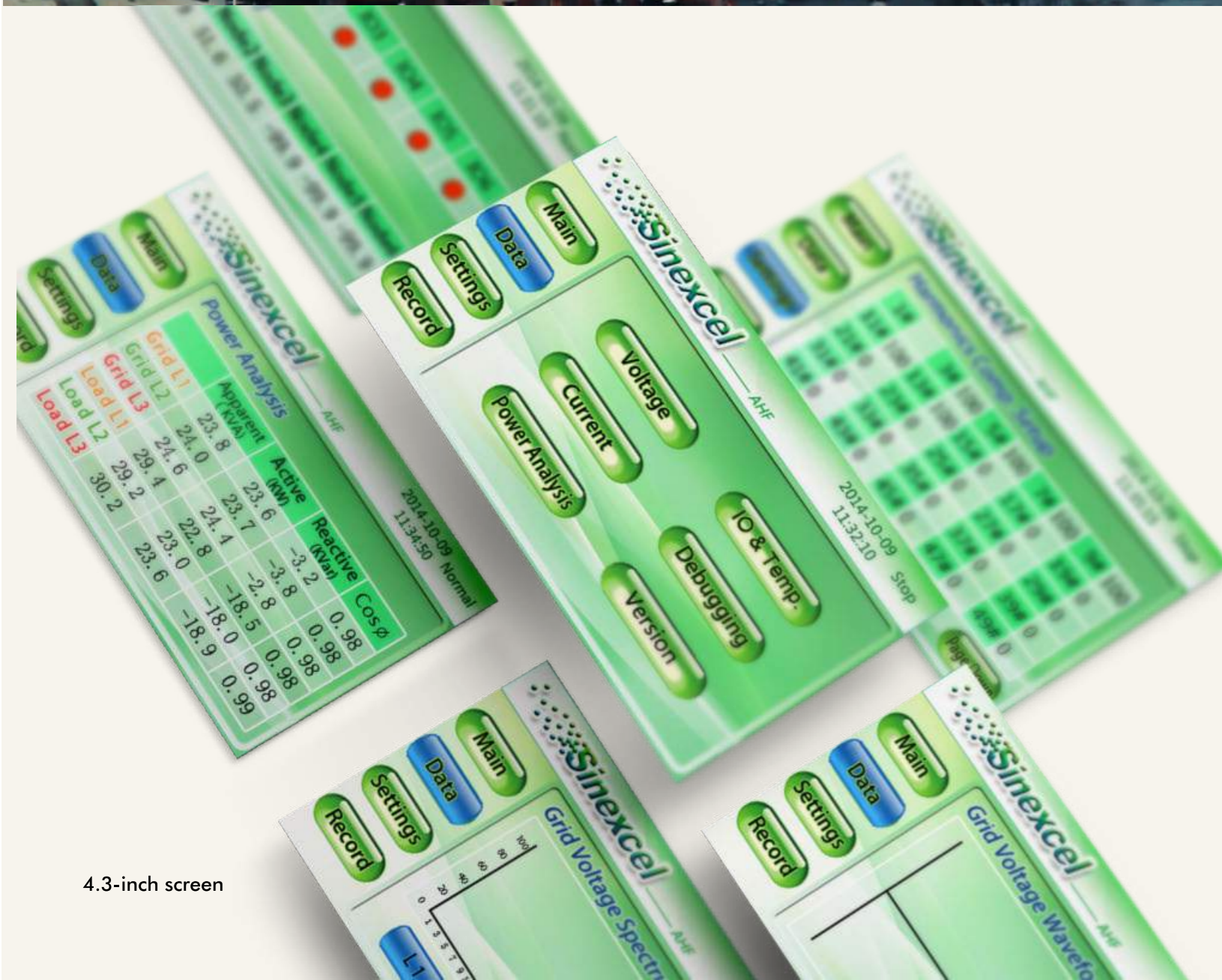

4.3-inch screen



Centralized monitoring System

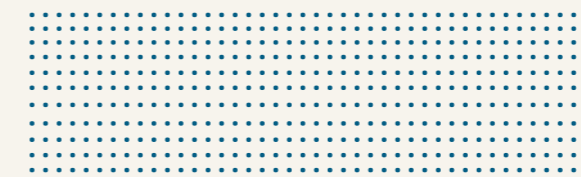

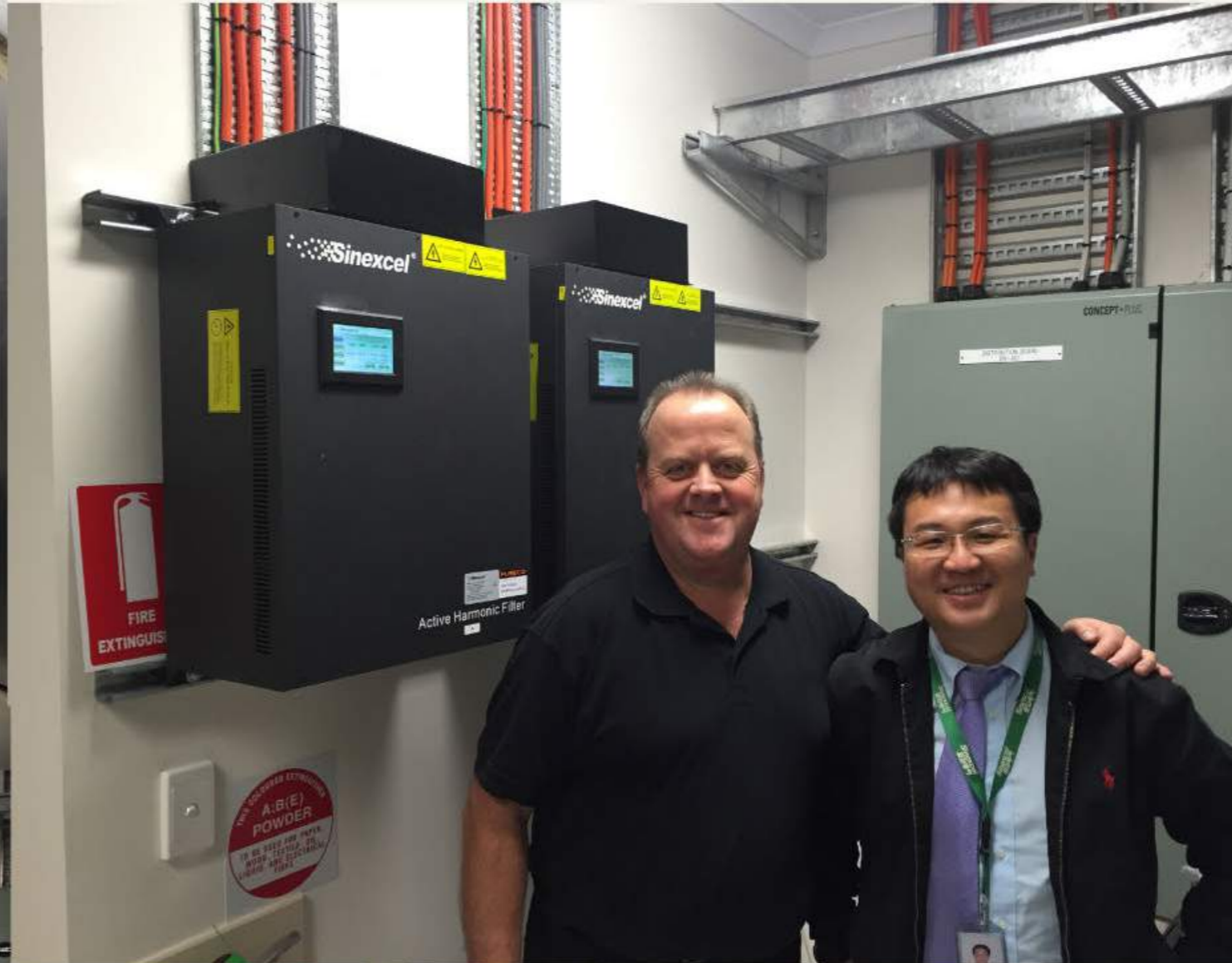

GLOBAL APPLICATION

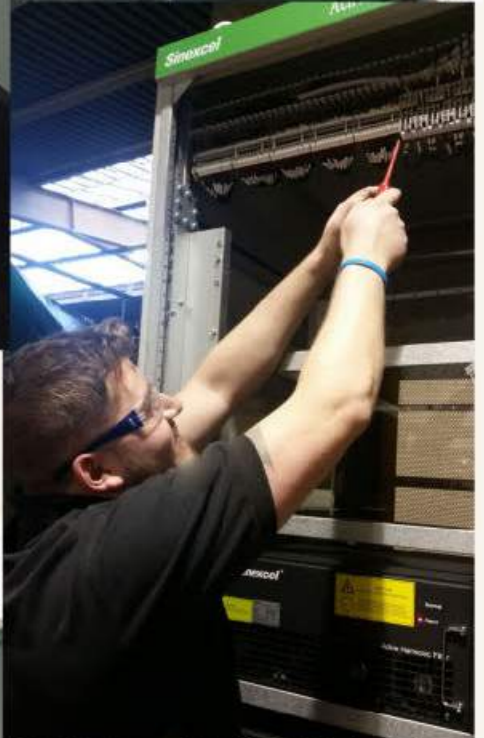



Industrial Manufacturing

Food and beverage, plastic, paper, semiconductor, chemistry, pharmacy,
paper, cement, oil drilling, automotive



Infrastructure

Airport-metro and railway, tunnel, water treatment, schools/campus,
museums, hospital, government building

More than 2million Ampere installation around the world

Application cover Automation Manufacturing, Infrastructure, ECO building, IDC

Application cover indoor/outdoor, high altitude (hot cold) mechanical environment/dusty
application, land/offshore severe environment



ECO Building

Skyscraper-Commercial building, shopping mall, apartments



IDC

Telecom, bank, internet companies



Canada, Hylife Food, AHF 1440A

Industrial Manufacturing

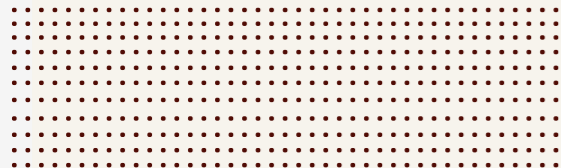

The United Kingdom, Glabina cheese, AHF 350A

Infrastructure

Australia, Sydney Opera house, AHF 200A



China, Beijing Tian An Men Square, AHF 440





Hong Kong Airport, AHF 150A



Dubai Airport, AHF 700A



Singapore Airport, AHF 150A



Goteborg Airport, SVG 270kVAr by invert based PQ

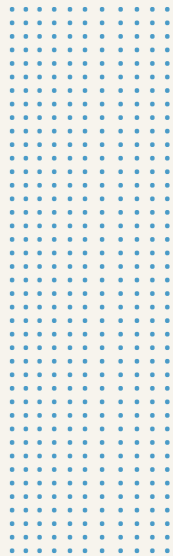

Infrastructure

ECO building

Singapore, Microsoft Headquarter of Southeast Asia, AHF 1800A



IDC



South Korea
Daegu bank AHF 150A/SVG 400kVAr



HongKong(China)
China Unicom Data Centre, AHF 4425A

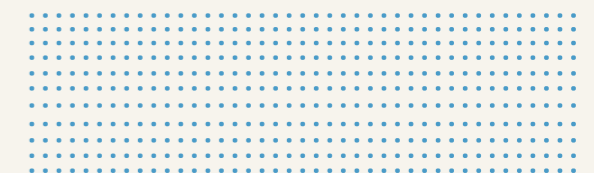



GLOBAL APPLICATION

Sinexcel AHF application covers Asia, Oceania, Europe, Africa, North America, South America.